

**NTA JEE Mains Jan 2026**

Application No	260310229343
Candidate Name	ANUBHAV LABH
Roll No.	UP090115404
Test Date	28/01/2026
Test Time	3:00 PM - 6:00 PM
Subject	B. Tech

Section : **Mathematics Section A****Q.1**

Let  $y = y(x)$  be the solution of the differential equation  $x \frac{dy}{dx} - y = x^2 \cot x$ ,  $x \in (0, \pi)$ . If  $y\left(\frac{\pi}{2}\right) = \frac{\pi}{2}$ , then

$6y\left(\frac{\pi}{6}\right) - 8y\left(\frac{\pi}{4}\right)$  is equal to :

- Options
1.  $\pi$
  2.  $-3\pi$
  3.  $-\pi$
  4.  $3\pi$

Question Type : **MCQ**Question ID : **8606541669**Option 1 ID : **8606545684**Option 2 ID : **8606545685**Option 3 ID : **8606545683**Option 4 ID : **8606545686**Status : **Answered**Chosen Option : **3**

**Q.2**

Let the arithmetic mean of  $\frac{1}{a}$  and  $\frac{1}{b}$  be  $\frac{5}{16}$ ,  $a > 2$ . If  $\alpha$  is such that  $a, 4, \alpha, b$  are in A.P., then the equation  $\alpha x^2 - ax + 2(\alpha - 2b) = 0$  has :

**Options**

1. both roots in the interval  $(-2, 0)$
2. one root in  $(0, 2)$  and another in  $(-4, -2)$
3. complex roots of magnitude less than 2
4. one root in  $(1, 4)$  and another in  $(-2, 0)$

Question Type : **MCQ**Question ID : **8606541654**Option 1 ID : **8606545624**Option 2 ID : **8606545626**Option 3 ID : **8606545623**Option 4 ID : **8606545625**Status : **Not Answered**

Chosen Option : --

**Q.3**

Let  $f(x) = \int \frac{dx}{x^{\left(\frac{2}{3}\right)} + 2x^{\left(\frac{1}{2}\right)}}$  be such that  $f(0) = -26 + 24 \log_e(2)$ . If  $f(1) = a + b \log_e(3)$ , where  $a, b \in \mathbf{Z}$ ,

then  $a + b$  is equal to :

**Options**

1.  $-5$
2.  $-26$
3.  $-11$
4.  $-18$

Question Type : **MCQ**

Question ID : **8606541668**

Option 1 ID : **8606545682**

Option 2 ID : **8606545679**

Option 3 ID : **8606545681**

Option 4 ID : **8606545680**

Status : **Not Attempted and  
Marked For Review**

Chosen Option : --

**Q.4** Considering the principal values of inverse trigonometric functions, the value of the expression

$$\tan\left(2\sin^{-1}\left(\frac{2}{\sqrt{13}}\right) - 2\cos^{-1}\left(\frac{3}{\sqrt{10}}\right)\right) \text{ is equal to :}$$

**Options**

1.  $\frac{33}{56}$
2.  $-\frac{16}{63}$
3.  $\frac{16}{63}$
4.  $-\frac{33}{56}$

Question Type : **MCQ**

Question ID : **8606541661**

Option 1 ID : **8606545652**

Option 2 ID : **8606545653**

Option 3 ID : **8606545651**

Option 4 ID : **8606545654**

Status : **Answered**

Chosen Option : **1**

**Q.5** An ellipse has its center at  $(1, -2)$ , one focus at  $(3, -2)$  and one vertex at  $(5, -2)$ . Then the length of its latus rectum is :

**Options**

1.  $4\sqrt{3}$

2.  $6\sqrt{3}$

3.  $\frac{16}{\sqrt{3}}$

4.  $6$

Question Type : **MCQ**

Question ID : **8606541659**

Option 1 ID : **8606545645**

Option 2 ID : **8606545643**

Option 3 ID : **8606545644**

Option 4 ID : **8606545646**

Status : **Answered**

Chosen Option : **4**

Q.6

Let  $f(x) = \lim_{\theta \rightarrow 0} \left( \frac{\cos \pi x - x^{\left(\frac{2}{\theta}\right)} \sin(x-1)}{1 + x^{\left(\frac{2}{\theta}\right)} (x-1)} \right), x \in \mathbf{R}$ . Consider the following two statements :

(I)  $f(x)$  is discontinuous at  $x = 1$ .

(II)  $f(x)$  is continuous at  $x = -1$ .

Then,

Options

1. Both (I) and (II) are True
2. Neither (I) nor (II) is True
3. Only (II) is True
4. Only (I) is True

Question Type : **MCQ**

Question ID : **8606541666**

Option 1 ID : **8606545673**

Option 2 ID : **8606545674**

Option 3 ID : **8606545672**

Option 4 ID : **8606545671**

Status : **Not Answered**

Chosen Option : --

**Q.7** Let A be the focus of the parabola  $y^2 = 8x$ . Let the line  $y = mx + c$  intersect the parabola at two distinct points B and C. If the centroid of the triangle ABC is  $\left(\frac{7}{3}, \frac{4}{3}\right)$ , then  $(BC)^2$  is equal to :

- Options**
1. 32
  2. 89
  3. 41
  4. 80

Question Type : **MCQ**

Question ID : **8606541663**

Option 1 ID : **8606545659**

Option 2 ID : **8606545662**

Option 3 ID : **8606545660**

Option 4 ID : **8606545661**

Status : **Answered**

Chosen Option : **4**

**Q.8** The sum of the coefficients of  $x^{499}$  and  $x^{500}$  in  $(1+x)^{1000} + x(1+x)^{999} + x^2(1+x)^{998} + \dots + x^{1000}$  is :

**Options**

1.  $^{1002}C_{501}$

2.  $^{1002}C_{500}$

3.  $^{1001}C_{501}$

4.  $^{1000}C_{501}$

Question Type : **MCQ**

Question ID : **8606541656**

Option 1 ID : **8606545631**

Option 2 ID : **8606545632**

Option 3 ID : **8606545634**

Option 4 ID : **8606545633**

Status : **Answered**

Chosen Option : **2**

Q.9

$$\frac{6}{3^{26}} + \frac{10 \cdot 1}{3^{25}} + \frac{10 \cdot 2}{3^{24}} + \frac{10 \cdot 2^2}{3^{23}} + \dots + \frac{10 \cdot 2^{24}}{3}$$
 is equal to :

Options

1.  $2^{25}$
2.  $3^{26}$
3.  $2^{26}$
4.  $3^{25}$

Question Type : **MCQ**Question ID : **8606541655**Option 1 ID : **8606545629**Option 2 ID : **8606545628**Option 3 ID : **8606545630**Option 4 ID : **8606545627**Status : **Answered**Chosen Option : **3**

**Q.10**

Let  $[\cdot]$  denote the greatest integer function. Then  $\int_{-\frac{\pi}{2}}^{\frac{\pi}{2}} \left( \frac{12(3+[x])}{3+[\sin x]+[\cos x]} \right) dx$  is equal to :

**Options**

1.  $15\pi + 4$
2.  $12\pi + 5$
3.  $11\pi + 2$
4.  $13\pi + 1$

Question Type : **MCQ**Question ID : **8606541667**Option 1 ID : **8606545675**Option 2 ID : **8606545678**Option 3 ID : **8606545677**Option 4 ID : **8606545676**Status : **Answered**Chosen Option : **3**

**Q.11** Let P be a point in the plane of the vectors  $\vec{AB} = 3\hat{i} + \hat{j} - \hat{k}$  and  $\vec{AC} = \hat{i} - \hat{j} + 3\hat{k}$  such that P is equidistant from the lines AB and AC. If  $|\vec{AP}| = \frac{\sqrt{5}}{2}$ , then the area of the triangle ABP is :

**Options**

1.  $\frac{\sqrt{26}}{4}$
2. 2
3.  $\frac{3}{2}$
4.  $\frac{\sqrt{30}}{4}$

Question Type : **MCQ**

Question ID : **8606541664**

Option 1 ID : **8606545664**

Option 2 ID : **8606545666**

Option 3 ID : **8606545663**

Option 4 ID : **8606545665**

Status : **Not Answered**

Chosen Option : --

**Q.12** Given below are two statements :

**Statement I:** The function  $f: \mathbf{R} \rightarrow \mathbf{R}$  defined by  $f(x) = \frac{x}{1 + |x|}$  is one-one.

**Statement II:** The function  $f: \mathbf{R} \rightarrow \mathbf{R}$  defined by  $f(x) = \frac{x^2 + 4x - 30}{x^2 - 8x + 18}$  is many-one.

In the light of the above statements, choose the **correct answer** from the options given below :

**Options**

1. Both **Statement I** and **Statement II** are true
2. Both **Statement I** and **Statement II** are false
3. **Statement I** is true but **Statement II** is false
4. **Statement I** is false but **Statement II** is true

Question Type : **MCQ**

Question ID : **8606541652**

Option 1 ID : **8606545615**

Option 2 ID : **8606545616**

Option 3 ID : **8606545617**

Option 4 ID : **8606545618**

Status : **Answered**

Chosen Option : **4**

**Q.13** The sum of all the elements in the range of  $f(x) = \text{Sgn}(\sin x) + \text{Sgn}(\cos x) + \text{Sgn}(\tan x) + \text{Sgn}(\cot x)$ ,

$x \neq \frac{n\pi}{2}, n \in \mathbf{Z}$ , where  $\text{Sgn}(t) = \begin{cases} 1, & \text{if } t > 0 \\ -1, & \text{if } t < 0 \end{cases}$ , is :

**Options**

1. 0
2. 2
3. 4
4. -2

Question Type : **MCQ**

Question ID : **8606541651**

Option 1 ID : **8606545614**

Option 2 ID : **8606545611**

Option 3 ID : **8606545612**

Option 4 ID : **8606545613**

Status : **Answered**

Chosen Option : **3**

**Q.14** Let the circle  $x^2 + y^2 = 4$  intersect  $x$ -axis at the points  $A(a, 0)$ ,  $a > 0$  and  $B(b, 0)$ . Let  $P(2 \cos \alpha, 2 \sin \alpha)$ ,  $0 < \alpha < \frac{\pi}{2}$  and  $Q(2 \cos \beta, 2 \sin \beta)$  be two points such that  $(\alpha - \beta) = \frac{\pi}{2}$ . Then the point of intersection of  $AQ$  and  $BP$  lies on :

**Options**

1.  $x^2 + y^2 - 4y - 4 = 0$
2.  $x^2 + y^2 - 4x - 4 = 0$
3.  $x^2 + y^2 - 4x - 4y - 4 = 0$
4.  $x^2 + y^2 - 4x - 4y = 0$

Question Type : **MCQ**

Question ID : **8606541660**

Option 1 ID : **8606545648**

Option 2 ID : **8606545647**

Option 3 ID : **8606545649**

Option 4 ID : **8606545650**

Status : **Not Attempted and  
Marked For Review**

Chosen Option : --

Q.15

Let

$$A = \{z \in \mathbb{C} : |z - 2| \leq 4\} \text{ and}$$

$$B = \{z \in \mathbb{C} : |z - 2| + |z + 2| = 5\}.$$

Then the max  $\{|z_1 - z_2| : z_1 \in A \text{ and } z_2 \in B\}$  is :

Options

1.  $\frac{17}{2}$
2.  $\frac{15}{2}$
3. 9
4. 8

Question Type : **MCQ**Question ID : **8606541653**Option 1 ID : **8606545621**Option 2 ID : **8606545619**Option 3 ID : **8606545622**Option 4 ID : **8606545620**Status : **Not Answered**

Chosen Option : --

**Q.16**

Given below are two statements :

**Statement I :**  $25^{13} + 20^{13} + 8^{13} + 3^{13}$  is divisible by 7.

**Statement II :** The integral part of  $(7 + 4\sqrt{3})^{25}$  is an odd number.

In the light of the above statements, choose the **correct answer** from the options given below :

**Options**

1. **Both Statement I and Statement II are false**
2. **Statement I is false but Statement II is true**
3. **Statement I is true but Statement II is false**
4. **Both Statement I and Statement II are true**

Question Type : **MCQ**

Question ID : **8606541657**

Option 1 ID : **8606545636**

Option 2 ID : **8606545638**

Option 3 ID : **8606545637**

Option 4 ID : **8606545635**

Status : **Not Answered**

Chosen Option : --

**Q.17**

Let the ellipse  $E: \frac{x^2}{144} + \frac{y^2}{169} = 1$  and the hyperbola  $H: \frac{x^2}{16} - \frac{y^2}{\lambda^2} = -1$  have the same foci. If  $e$  and  $L$  respectively denote the eccentricity and the length of the latus rectum of  $H$ , then the value of  $24(e + L)$  is :

**Options**

1. 296
2. 148
3. 67
4. 126

Question Type : **MCQ**Question ID : **8606541662**Option 1 ID : **8606545658**Option 2 ID : **8606545657**Option 3 ID : **8606545655**Option 4 ID : **8606545656**Status : **Answered**Chosen Option : **1**

Q.18

The probability distribution of a random variable X is given below :

X	4k	$\frac{30}{7}k$	$\frac{32}{7}k$	$\frac{34}{7}k$	$\frac{36}{7}k$	$\frac{38}{7}k$	$\frac{40}{7}k$	6k
P(X)	$\frac{2}{15}$	$\frac{1}{15}$	$\frac{2}{15}$	$\frac{1}{5}$	$\frac{1}{15}$	$\frac{2}{15}$	$\frac{1}{5}$	$\frac{1}{15}$

If  $E(X) = \frac{263}{15}$ , then  $P(X < 20)$  is equal to :

Options

1.  $\frac{14}{15}$
2.  $\frac{11}{15}$
3.  $\frac{8}{15}$
4.  $\frac{3}{5}$

Question Type : MCQ

Question ID : 8606541658

Option 1 ID : 8606545642

Option 2 ID : 8606545641

Option 3 ID : 8606545639

Option 4 ID : 8606545640

Status : **Not Attempted and  
Marked For Review**

Chosen Option : --

**Q.19** Let  $P_1 : y = 4x^2$  and  $P_2 : y = x^2 + 27$  be two parabolas. If the area of the bounded region enclosed between  $P_1$  and  $P_2$  is six times the area of the bounded region enclosed between the line  $y = \alpha x$ ,  $\alpha > 0$  and  $P_1$ , then  $\alpha$  is equal to :

**Options**

1. 6
2. 12
3. 8
4. 15

Question Type : **MCQ**

Question ID : **8606541670**

Option 1 ID : **8606545687**

Option 2 ID : **8606545689**

Option 3 ID : **8606545688**

Option 4 ID : **8606545690**

Status : **Not Answered**

Chosen Option : --

**Q.20**

Let Q(a, b, c) be the image of the point P(3, 2, 1) in the line  $\frac{x-1}{1} = \frac{y}{2} = \frac{z-1}{1}$ . Then the distance of

Q from the line  $\frac{x-9}{3} = \frac{y-9}{2} = \frac{z-5}{-2}$  is

**Options**

1. 7
2. 5
3. 8
4. 6

Question Type : **MCQ**Question ID : **8606541665**Option 1 ID : **8606545670**Option 2 ID : **8606545668**Option 3 ID : **8606545667**Option 4 ID : **8606545669**Status : **Answered**Chosen Option : **1**Section : **Mathematics Section B**

Q  
2  
1  
Let  $A = \begin{bmatrix} 3 & -4 \\ 1 & -1 \end{bmatrix}$  and B be two matrices such that  $A^{100} = 100B + I$ . Then the sum of all the elements of  $B^{100}$  is \_\_\_\_\_

G  
i  
v  
e  
n  
A  
n  
s  
w  
e  
r  
:

Question Type : SA

Question ID : 8606541671

Status : Answered

Q  
2  
2  
Let  $f$  be a differentiable function satisfying  $f(x) = 1 - 2x + \int_0^x e^{(x-t)} f(t) dt, x \in \mathbf{R}$  and let  $g(x) = \int_0^x (f(t) + 2)^{15} (t - 4)^6 (t + 12)^{17} dt, x \in \mathbf{R}$ . If p and q are respectively the points of local minima and local maxima of g, then the value of  $|p + q|$  is equal to \_\_\_\_\_.

G  
i  
v  
e  
n  
A  
n  
s  
w  
e  
r  
:

Question Type : SA

Question ID : 8606541675

Status : Not Answered

Q  
·  
2 If  $\sum_{r=1}^{25} \left( \frac{r}{r^4 + r^2 + 1} \right) = \frac{p}{q}$ , where p and q are positive integers such that  $\gcd(p, q) = 1$ , then p + q is  
3 equal to \_\_\_\_\_.

G--  
iv  
e  
n  
A  
n  
s  
w  
e  
r  
:

Question Type : SA

Question ID : 8606541672

Status : Not Answered

Q  
·  
2 Three persons enter in a lift at the ground floor. The lift will go upto 10<sup>th</sup> floor. The number of ways,  
4 in which the three persons can exit the lift at three different floors, if the lift does not stop at first, second and third floors, is equal to \_\_\_\_\_.

G--  
iv  
e  
n  
A  
n  
s  
w  
e  
r  
:

Question Type : SA

Question ID : 8606541673

Status : Not Answered

Q

2  
5

If the distance of the point  $P(43, \alpha, \beta)$ ,  $\beta < 0$ , from the line  $\vec{r} = 4\hat{i} - \hat{k} + \mu(2\hat{i} + 3\hat{k})$ ,  $\mu \in \mathbf{R}$  along a line with direction ratios  $3, -1, 0$  is  $13\sqrt{10}$ , then  $\alpha^2 + \beta^2$  is equal to \_\_\_\_\_

G--  
iv  
e  
n  
A  
n  
s  
w  
e  
r  
:

Question Type : SA

Question ID : 8606541674

Status : Not Answered

Section : Physics Section A

**Q.26**

Which one of the following is **not** a measurable quantity ?

**Options**

1. Displacement current
2. Voltage
3. Voltage difference
4. Resistance

Question Type : **MCQ**Question ID : **8606541689**Option 1 ID : **8606545748**Option 2 ID : **8606545749**Option 3 ID : **8606545750**Option 4 ID : **8606545751**Status : **Answered**Chosen Option : **2**

Q.27

As shown in the figure, a spring is kept in a stretched position with some extension by holding the masses 1 kg and 0.2 kg with a separation more than spring natural length and are released. Assuming the horizontal surface to be frictionless, the angular frequency (in SI unit) of the system is :

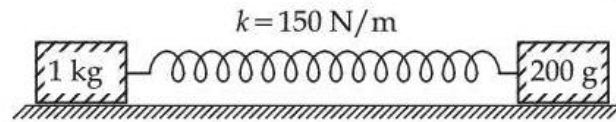

Options

1. 30
2. 5
3. 27
4. 20

Question Type : **MCQ**Question ID : **8606541678**Option 1 ID : **8606545705**Option 2 ID : **8606545704**Option 3 ID : **8606545706**Option 4 ID : **8606545707**Status : **Answered**Chosen Option : **1**

**Q.28**

The time period of a simple harmonic oscillator is  $T = 2\pi\sqrt{\frac{k}{m}}$ . Measured value of mass ( $m$ ) of the object is 10 g with an accuracy of 10 mg and time for 50 oscillations of the spring is found to be 60 s using a watch of 2 s resolution. Percentage error in determination of spring constant ( $k$ ) is \_\_\_\_\_%.

**Options**

1. 7.60
2. 3.35
3. 6.76
4. 3.43

Question Type : **MCQ**Question ID : **8606541677**Option 1 ID : **8606545702**Option 2 ID : **8606545701**Option 3 ID : **8606545700**Option 4 ID : **8606545703**Status : **Not Attempted and  
Marked For Review**

Chosen Option : --

- Q.29** A long cylindrical conductor with large cross section carries an electric current distributed uniformly over its cross-section. Magnetic field due to this current is :
- A. maximum at either ends of the conductor and minimum at the midpoint
  - B. maximum at the axis of the conductor
  - C. minimum at the surface of the conductor
  - D. minimum at the axis of the conductor
  - E. same at all points in the cross-section of the conductor
- Choose the **correct** answer from the options given below :

**Options**

1. E Only
2. A, D Only
3. D Only
4. B, C Only

Question Type : **MCQ**

Question ID : **8606541688**

Option 1 ID : **8606545747**

Option 2 ID : **8606545744**

Option 3 ID : **8606545745**

Option 4 ID : **8606545746**

Status : **Answered**

Chosen Option : **2**

**Q.30**

A Wheatstone bridge is initially at room temperature and all arms of the bridge have same value of resistances ( $R_1 = R_2 = R_3 = R_4$ ). When  $R_3$  resistance is heated to some temperature, its resistance value has gone up by 10%. The potential difference ( $V_a - V_b$ ) (after  $R_3$  is heated) is \_\_\_\_\_ V.

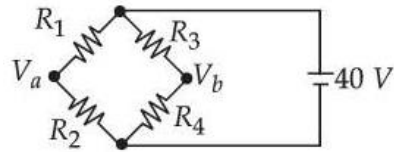
**Options**

1. 0.95
2. 2
3. 1.05
4. 0

Question Type : **MCQ**Question ID : **8606541687**Option 1 ID : **8606545743**Option 2 ID : **8606545742**Option 3 ID : **8606545740**Option 4 ID : **8606545741**Status : **Answered**Chosen Option : **1**

Q.31

A biconvex lens is formed by using two thin planoconvex lenses, as shown in the figure. The refractive index and radius of curved surfaces are also mentioned in figure. When an object is placed on the left side of lens at a distance of 30 cm from the biconvex lens, the magnification of the image will be :

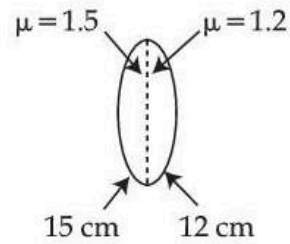

Options

1.  $-2$
2.  $+2.5$
3.  $+2$
4.  $-2.5$

Question Type : **MCQ**Question ID : **8606541692**Option 1 ID : **8606545761**Option 2 ID : **8606545763**Option 3 ID : **8606545760**Option 4 ID : **8606545762**Status : **Answered**Chosen Option : **1**

Q.32

A small block of mass  $m$  slides down from the top of a frictionless inclined surface, while the inclined plane is moving towards left with constant acceleration  $a_0$ . The angle between the inclined plane and ground is  $\theta$  and its base length is  $L$ . Assuming that initially the small block is at the top of the inclined plane, the time it takes to reach the lowest point of the inclined plane is \_\_\_\_\_.

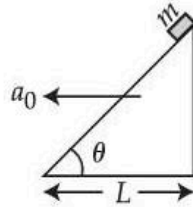

Options

1.  $\sqrt{\frac{4L}{g \sin 2\theta - a_0 (1 + \cos 2\theta)}}$

2.  $\sqrt{\frac{4L}{g \cos^2 \theta - a_0 \sin \theta \cos \theta}}$

3.  $\sqrt{\frac{2L}{g \sin 2\theta - a_0 (1 + \cos 2\theta)}}$

4.  $\sqrt{\frac{2L}{g \sin \theta - a_0 \cos \theta}}$

Question Type : MCQ

Question ID : 8606541679

Option 1 ID : 8606545708

Option 2 ID : 8606545710

Option 3 ID : 8606545709

Option 4 ID : 8606545711

Status : Answered

Chosen Option : 1

**Q.33** Number of photons of equal energy emitted per second by a 6 mW laser source operating at 663 nm is \_\_\_\_\_. (Given :  $h=6.63 \times 10^{-34}$  J.s and  $c=3 \times 10^8$  m/s)

**Options**

1.  $5 \times 10^{16}$
2.  $5 \times 10^{15}$
3.  $10 \times 10^{15}$
4.  $2 \times 10^{16}$

Question Type : **MCQ**

Question ID : **8606541693**

Option 1 ID : **8606545767**

Option 2 ID : **8606545764**

Option 3 ID : **8606545765**

Option 4 ID : **8606545766**

Status : **Answered**

Chosen Option : **4**

**Q.34** A nucleus has mass number  $\alpha$  and radius  $R_\alpha$ . Another nucleus has mass number  $\beta$  and radius  $R_\beta$ .  
If  $\beta = 8\alpha$  then  $R_\alpha / R_\beta$  is :

**Options**

1. 2
2. 1
3. 8
4. 0.5

Question Type : **MCQ**

Question ID : **8606541694**

Option 1 ID : **8606545771**

Option 2 ID : **8606545769**

Option 3 ID : **8606545770**

Option 4 ID : **8606545768**

Status : **Answered**

Chosen Option : **4**

**Q.35** The mean free path of a molecule of diameter  $5 \times 10^{-10}$  m at the temperature  $41^\circ\text{C}$  and pressure  $1.38 \times 10^5$  Pa, is given as \_\_\_\_\_ m. (Given  $k_B = 1.38 \times 10^{-23}$  J/K).

**Options**

1.  $2\sqrt{2} \times 10^{-8}$
2.  $2 \times 10^{-8}$
3.  $10\sqrt{2} \times 10^{-8}$
4.  $2\sqrt{2} \times 10^{-10}$

Question Type : **MCQ**

Question ID : **8606541684**

Option 1 ID : **8606545729**

Option 2 ID : **8606545731**

Option 3 ID : **8606545728**

Option 4 ID : **8606545730**

Status : **Answered**

Chosen Option : **1**

**Q.36**

When the position vector  $\vec{r} = x\hat{i} + y\hat{j} + z\hat{k}$  changes sign as  $-\vec{r}$ , which one of the following vector will not flip under sign change ?

**Options**

1. Velocity
2. Angular momentum
3. Acceleration
4. Linear momentum

Question Type : **MCQ**Question ID : **8606541681**Option 1 ID : **8606545716**Option 2 ID : **8606545718**Option 3 ID : **8606545717**Option 4 ID : **8606545719**Status : **Answered**Chosen Option : **3**

**Q.37** The speed of a longitudinal wave in a metallic bar is 400 m/s. If the density and Young's modulus of the bar material are increased by 0.5% and 1%, respectively then the speed of the wave is changed approximately to \_\_\_\_\_ m/s.

**Options**

1. 399
2. 398
3. 401
4. 402

Question Type : **MCQ**

Question ID : **8606541683**

Option 1 ID : **8606545727**

Option 2 ID : **8606545724**

Option 3 ID : **8606545725**

Option 4 ID : **8606545726**

Status : **Not Attempted and  
Marked For Review**

Chosen Option : --

Q.38

Match List - I with List - II.

List - I

- A. Coefficient of viscosity
- B. Surface tension
- C. Pressure
- D. Surface energy

List - II

- I.  $[ML^{-1}T^{-2}]$
- II.  $[ML^2T^{-2}]$
- III.  $[ML^0T^{-2}]$
- IV.  $[ML^{-1}T^{-1}]$

Choose the **correct** answer from the options given below :

Options

1. A-I, B-III, C-II, D-IV
2. A-IV, B-III, C-I, D-II
3. A-I, B-II, C-IV, D-III
4. A-IV, B-I, C-II, D-III

Question Type : **MCQ**Question ID : **8606541682**Option 1 ID : **8606545722**Option 2 ID : **8606545720**Option 3 ID : **8606545721**Option 4 ID : **8606545723**Status : **Answered**Chosen Option : **2**

**Q.39** A plane electromagnetic wave is moving in free space with velocity  $c = 3 \times 10^8$  m/s and its electric field is given as  $\vec{E} = 54 \sin(kz - \omega t) \hat{j}$  V/m, where  $\hat{j}$  is the unit vector along  $y$ -axis. The magnetic field vector  $\vec{B}$  of the wave is :

**Options**

1.  $1.4 \times 10^{-7} \sin(kz - \omega t) \hat{k}$  T
2.  $-1.8 \times 10^{-7} \sin(kz - \omega t) \hat{i}$  T
3.  $1.4 \times 10^{-7} \sin(kz - \omega t) \hat{i}$  T
4.  $+1.8 \times 10^{-7} \sin(kz - \omega t) \hat{i}$  T

Question Type : **MCQ**

Question ID : **8606541690**

Option 1 ID : **8606545753**

Option 2 ID : **8606545752**

Option 3 ID : **8606545755**

Option 4 ID : **8606545754**

Status : **Answered**

Chosen Option : **4**

**Q.40** Two p-n junction diodes  $D_1$  and  $D_2$  are connected as shown in figure.  $A$  and  $B$  are input signals and  $C$  is the output. The given circuit will function as a \_\_\_\_\_.

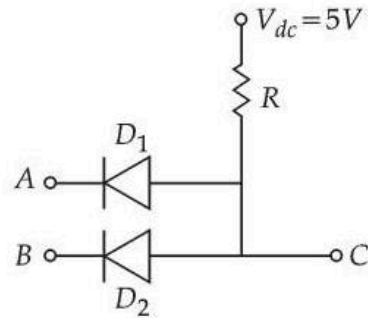

- Options**
1. NOR Gate
  2. OR Gate
  3. NAND Gate
  4. AND Gate

Question Type : **MCQ**

Question ID : **8606541695**

Option 1 ID : **8606545775**

Option 2 ID : **8606545772**

Option 3 ID : **8606545773**

Option 4 ID : **8606545774**

Status : **Not Answered**

Chosen Option : --

**Q.41** For a transparent prism, if the angle of minimum deviation is equal to its refracting angle, the refractive index  $n$  of the prism satisfies.

**Options**

1.  $n \geq 2$
2.  $\sqrt{2} < n < 2$
3.  $1 < n < 2$
4.  $\sqrt{2} < n < 2\sqrt{2}$

Question Type : **MCQ**

Question ID : **8606541691**

Option 1 ID : **8606545757**

Option 2 ID : **8606545759**

Option 3 ID : **8606545756**

Option 4 ID : **8606545758**

Status : **Answered**

Chosen Option : **3**

Q.42

A particle starts moving from time  $t=0$  and its coordinate is given as  $x(t) = 4t^3 - 3t$

- A. The particle returns to its original position (origin) 0.866 units later
- B. The particle is 1 unit away from origin at its turning point
- C. Acceleration of the particle is non-negative
- D. The particle is 0.5 units away from origin at its turning point
- E. Particle never turns back as acceleration is non-negative

Choose the **correct** answer from the options given below :

Options

- 1. A, C, D Only
- 2. C, E Only
- 3. A, B, C Only
- 4. A, C Only

Question Type : **MCQ**Question ID : **8606541680**Option 1 ID : **8606545713**Option 2 ID : **8606545715**Option 3 ID : **8606545714**Option 4 ID : **8606545712**Status : **Answered**Chosen Option : **3**

**Q.43** In an experiment, a set of reading are obtained as follows - 1.24 mm, 1.25 mm, 1.23 mm, 1.21 mm. The expected least count of the instrument used in recording these readings is \_\_\_\_\_ mm.

**Options**

1. 0.01
2. 0.1
3. 0.001
4. 0.05

Question Type : **MCQ**

Question ID : **8606541676**

Option 1 ID : **8606545699**

Option 2 ID : **8606545696**

Option 3 ID : **8606545697**

Option 4 ID : **8606545698**

Status : **Answered**

Chosen Option : **1**

**Q.44** Identify the correct statements :

- A. Effective capacitance of a series combination of capacitors is always smaller than the smallest capacitance of the capacitor in the combination.
- B. When a dielectric medium is placed between the charged plates of a capacitor, displacement of charges cannot occur due to insulation property of dielectric.
- C. Increasing of area of capacitor plate or decreasing of thickness of dielectric is an alternate method to increase the capacitance.
- D. For a point charge, concentric spherical shells centered at the location of the charge are equipotential surfaces.

Choose the **correct** answer from the options given below :

**Options**

- 1. B and D Only
- 2. C and D Only
- 3. A, B and C Only
- 4. A, C and D Only

Question Type : **MCQ**

Question ID : **8606541686**

Option 1 ID : **8606545737**

Option 2 ID : **8606545738**

Option 3 ID : **8606545736**

Option 4 ID : **8606545739**

Status : **Answered**

Chosen Option : **4**

**Q.45**

Identify the correct statements :

- A. Electrostatic field lines form closed loops .
- B. The electric field lines point radially outward when charge is greater than zero.
- C. The Gauss - Law is valid only for inverse - square force.
- D. The workdone in moving a charged particle in a static electric field around a closed path is zero.
- E. The motion of a particle under Coulomb's force must take place in a plane.

Choose the **correct** answer from the options given below :**Options**

- 1. A, B, C, D Only
- 2. A, C, E Only
- 3. B, C, D, E Only
- 4. A, B, D, E Only

Question Type : **MCQ**Question ID : **8606541685**Option 1 ID : **8606545732**Option 2 ID : **8606545734**Option 3 ID : **8606545733**Option 4 ID : **8606545735**Status : **Answered**Chosen Option : **4**Section : **Physics Section B**

Q  
4  
6  
A thermodynamic system is taken through the cyclic process  $ABC$  as shown in the figure. The total work done by the system during the cycle  $ABC$  is \_\_\_\_\_ J.

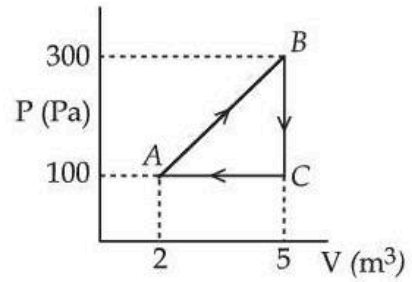

G 300

iv  
e  
n  
A  
n  
s  
w  
e  
r  
:

Question Type : SA

Question ID : 8606541699

Status : Answered

Q .  
4 A fly wheel having mass 3 kg and radius 5 m is free to rotate about a horizontal axis. A string having negligible mass is wound around the wheel and the loose end of the string is connected to 3 kg mass.  
7 The mass is kept at rest initially and released. Kinetic energy of the wheel when the mass descends by 3 m is \_\_\_\_\_ J. ( $g = 10 \text{ m/s}^2$ )

G 50

iv  
e  
n  
A  
n  
s  
w  
e  
r  
:

Question Type : SA

Question ID : 8606541696

Status : Answered

Q .  
4 Two tuning forks A and B are sounded together giving rise to 8 beats in 2 s. When fork A is loaded with wax, the beat frequency is reduced to 4 beats in 2 s. If the original frequency of tuning fork B is  
8 380 Hz then original frequency of tuning fork A is \_\_\_\_\_ Hz.

G --  
iv  
e  
n  
A  
n  
s  
w  
e  
r  
:

Question Type : SA

Question ID : 8606541697

Status : Not Answered

Q  
4  
9  
A beam of light consisting of wavelengths 650 nm and 550 nm illuminates the Young's double slits with separation of 2 mm such that the interference fringes are formed on a screen, placed at a distance of 1.2 m from the slits. The least distance of a point from the central maximum, where the bright fringes due to both the wavelengths coincide, is \_\_\_\_\_  $\times 10^{-5}$  m.

G 429

iv  
e  
n  
A  
n  
s  
w  
e  
r  
:

Question Type : SA

Question ID : 8606541700

Status : Answered

Q  
5  
0  
An inductor stores 16 J of magnetic field energy and dissipates 32 W of thermal energy due to its resistance when an a.c. current of 2 A (rms) and frequency 50 Hz flows through it. The ratio of inductive reactance to its resistance is \_\_\_\_\_. ( $\pi=3.14$ )

G 314

iv  
e  
n  
A  
n  
s  
w  
e  
r  
:

Question Type : SA

Question ID : 8606541698

Status : Answered

Section : Chemistry Section A

**Q.51** Total number of alkali insoluble solid sulphonamides obtained by reaction of given amines with Hinsberg's reagent is \_\_\_\_\_.

Aniline, N-Methylaniline, Methanamine, N, N – Dimethylmethanamine, N-Methyl methanamine, Phenylmethanamine, N-propylaniline, N-phenylaniline, N, N-Dimethylaniline, Allyl amine, Isopropyl amine

**Options**

1. 4
2. 8
3. 2
4. 5

Question Type : **MCQ**

Question ID : **8606541718**

Option 1 ID : **8606545850**

Option 2 ID : **8606545851**

Option 3 ID : **8606545852**

Option 4 ID : **8606545849**

Status : **Answered**

Chosen Option : **1**

Q.52

The cyclic cations having the same number of hyperconjugation are :

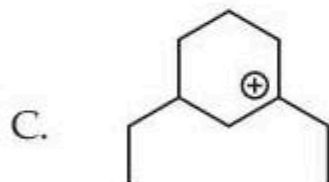
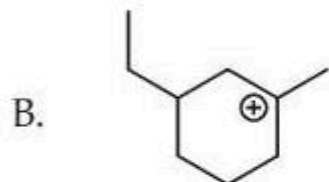

Choose the **correct** answer from the options given below :

Options

1. A and B Only
2. A and C Only
3. A, C and D only
4. B and C Only

Question Type : MCQ

Question ID : 8606541712

Option 1 ID : **8606545825**Option 2 ID : **8606545828**Option 3 ID : **8606545826**Option 4 ID : **8606545827**Status : **Answered**Chosen Option : **2****Q.53**

The plot of  $\log_{10} K$  vs  $\frac{1}{T}$  gives a straight line. The intercept and slope respectively are (where K is equilibrium constant).

**Options**

1.  $-\frac{\Delta H^{\circ}}{2 \cdot 303 R}$  ,  $\frac{\Delta S^{\circ}}{2 \cdot 303 R}$

2.  $\frac{2 \cdot 303 R}{\Delta H^{\circ}}$  ,  $\frac{2 \cdot 303 R}{\Delta S^{\circ}}$

3.  $-\frac{\Delta S^{\circ} R}{2 \cdot 303}$  ,  $\frac{\Delta H^{\circ} R}{2 \cdot 303}$

4.  $\frac{\Delta S^{\circ}}{2 \cdot 303 R}$  ,  $-\frac{\Delta H^{\circ}}{2 \cdot 303 R}$

Question Type : **MCQ**Question ID : **8606541703**Option 1 ID : **8606545789**Option 2 ID : **8606545791**Option 3 ID : **8606545790**Option 4 ID : **8606545792**Status : **Answered**Chosen Option : **4**

Q.54

The reactions which produce alcohol as the product are :

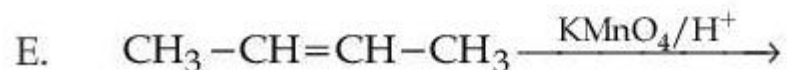
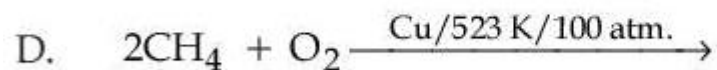
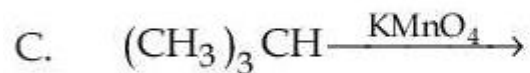
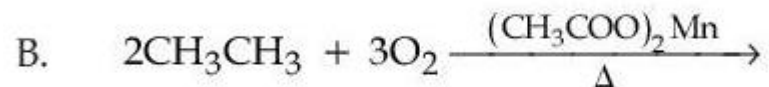
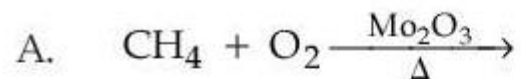

Choose the **correct** answer from the options given below :

Options

1. A, C and E Only
2. A and D Only
3. C and D Only
4. B, D and E Only

Question Type : **MCQ**

Question ID : **8606541714**

Option 1 ID : **8606545836**

Option 2 ID : **8606545833**

Option 3 ID : **8606545835**

Option 4 ID : **8606545834**

Status : **Answered**

Chosen Option : 2

**Q.55** Structures of four disaccharides are given below. Among the given disaccharides, the non-reducing sugar is :

**Options**

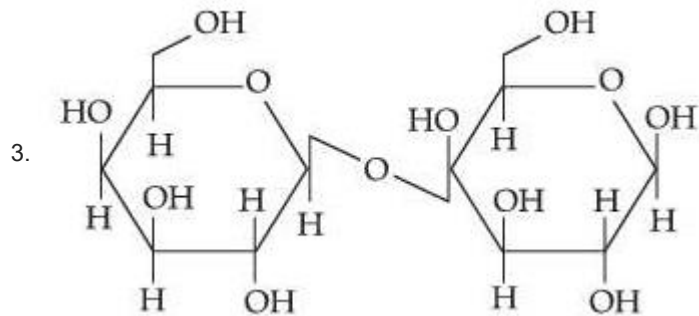
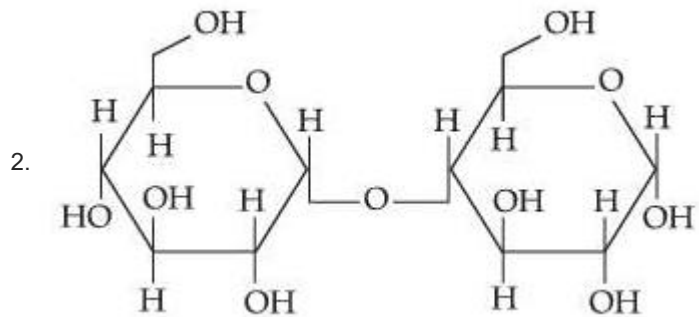
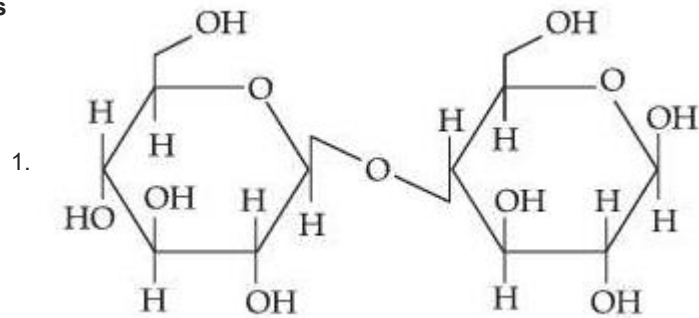

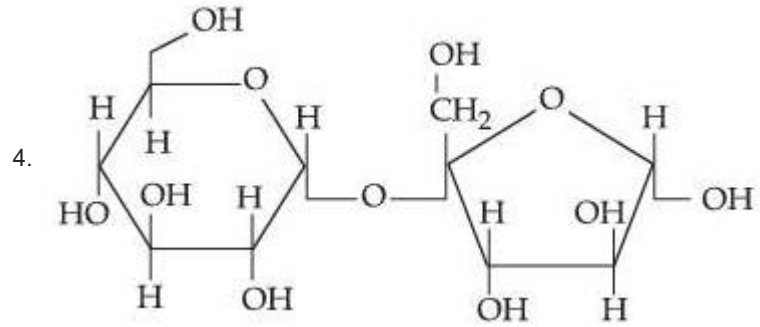

Question Type : **MCQ**

Question ID : **8606541719**

Option 1 ID : **8606545856**

Option 2 ID : **8606545853**

Option 3 ID : **8606545855**

Option 4 ID : **8606545854**

Status : **Answered**

Chosen Option : **2**

**Q.56** The correct increasing order of spin-only magnetic moment values of the complex ions  $[\text{MnBr}_4]^{2-}$  (A),  $[\text{Cu}(\text{H}_2\text{O})_6]^{2+}$  (B),  $[\text{Ni}(\text{CN})_4]^{2-}$  (C) and  $[\text{Ni}(\text{H}_2\text{O})_6]^{2+}$  (D) is :

**Options**

1.  $A = B < C < D$
2.  $C < B < D < A$
3.  $C = D < B < A$
4.  $A = B < D < C$

Question Type : **MCQ**

Question ID : **8606541710**

Option 1 ID : **8606545817**

Option 2 ID : **8606545820**

Option 3 ID : **8606545819**

Option 4 ID : **8606545818**

Status : **Answered**

Chosen Option : **2**

**Q.57** For the given reaction;

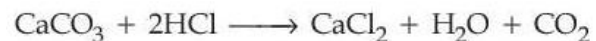

If 90 g  $\text{CaCO}_3$  is added to 300 mL of HCl which contains 38.55% HCl by mass and has density  $1.13 \text{ g mL}^{-1}$ , then which of the following option is **correct** ?

Given molar mass of H, Cl, Ca and O are 1, 35.5, 40 and 16  $\text{g mol}^{-1}$  respectively.

**Options**

1. 32.85 g of  $\text{CaCO}_3$  remains unreacted
2. 64.97 g of HCl remains unreacted
3. 97.30 g of HCl reacted
4. 60.32 g of HCl remains unreacted

Question Type : **MCQ**

Question ID : **8606541701**

Option 1 ID : **8606545783**

Option 2 ID : **8606545782**

Option 3 ID : **8606545784**

Option 4 ID : **8606545781**

Status : **Answered**

Chosen Option : **2**

**Q.58**

Consider the following aqueous solutions.

- I. 2.2 g Glucose in 125 mL of solution.
- II. 1.9 g Calcium chloride in 250 mL of solution.
- III. 9.0 g Urea in 500 mL of solution.
- IV. 20.5 g Aluminium sulphate in 750 mL of solution.

The **correct** increasing order of boiling point of these solutions will be :

[Given : Molar mass in  $\text{g mol}^{-1}$  : H = 1, C = 12, N = 14, O = 16, Cl = 35.5, Ca = 40, Al = 27 and S = 32]

**Options**

1. III < I < II < IV
2. II < III < IV < I
3. I < II < III < IV
4. II < III < I < IV

Question Type : **MCQ**

Question ID : **8606541704**

Option 1 ID : **8606545794**

Option 2 ID : **8606545796**

Option 3 ID : **8606545793**

Option 4 ID : **8606545795**

Status : **Not Attempted and  
Marked For Review**

Chosen Option : --

Q.59

Which of the following reaction is NOT correctly represented ?

Options

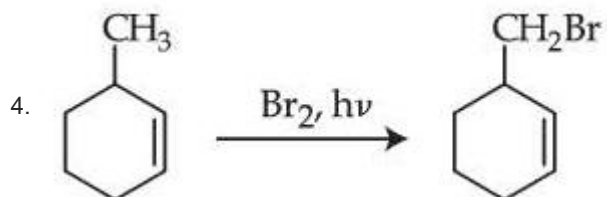
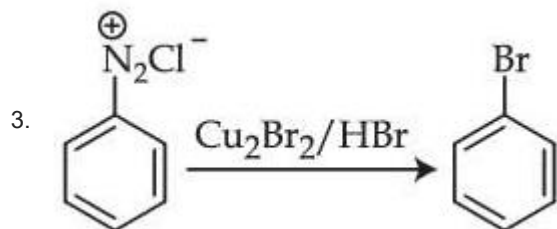
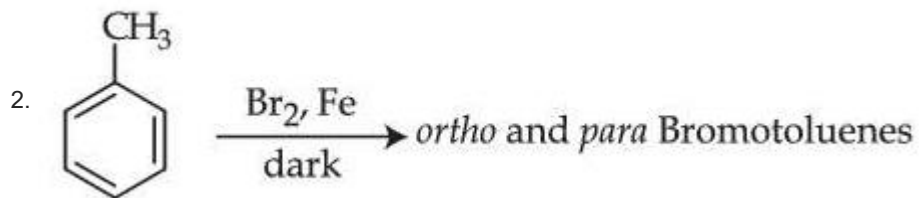
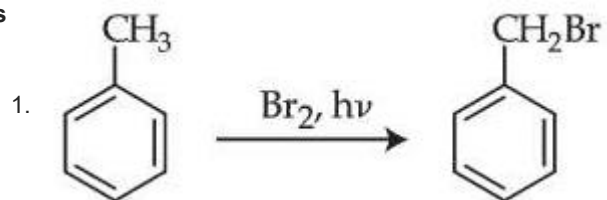

Question Type : MCQ

Question ID : 8606541715

Option 1 ID : 8606545838

Option 2 ID : 8606545839

Option 3 ID : 8606545840

Option 4 ID : 8606545837

Status : Answered

Chosen Option : 4

**Q.60** Observe the following equilibrium in a 1 L flask.

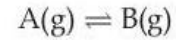

At T(K), the equilibrium concentrations of A and B are 0.5 M and 0.375 M respectively. 0.1 moles of A is added into the flask and heated to T(K) to establish the equilibrium again. The new equilibrium concentrations (in M) of A and B are respectively

**Options**

1. 0.742, 0.557.
2. 0.367, 0.275.
3. 0.53, 0.4.
4. 0.557, 0.418.

Question Type : **MCQ**

Question ID : **8606541705**

Option 1 ID : **8606545798**

Option 2 ID : **8606545799**

Option 3 ID : **8606545800**

Option 4 ID : **8606545797**

Status : **Answered**

Chosen Option : **4**

**Q.61** A student performed analysis of aliphatic organic compound 'X' which on analysis gave C = 61.01%, H = 15.25%, N = 23.74%.

This compound, on treatment with  $\text{HNO}_2/\text{H}_2\text{O}$  produced another compound 'Y' which did not contain any nitrogen atom. However, the compound 'Y' upon controlled oxidation produced another compound 'Z' that responded to iodoform test.

The structure of 'X' is :

Options

1.  $\begin{array}{c} \text{CH}_3 \backslash \\ \text{CH} - \text{NH}_2 \\ \text{CH}_3 / \end{array}$
2.  $\begin{array}{c} \text{Ph} - \text{CH} - \text{NH}_2 \\ | \\ \text{CH}_3 \end{array}$
3.  $\text{CH}_3\text{CH}_2\text{CH}_2\text{NH}_2$
4.  $\begin{array}{c} \text{CH}_3 - \text{CH}_2\text{CH} - \text{CH}_3 \\ | \\ \text{NH}_2 \end{array}$

Question Type : **MCQ**

Question ID : **8606541717**

Option 1 ID : **8606545848**

Option 2 ID : **8606545846**

Option 3 ID : **8606545845**

Option 4 ID : **8606545847**

Status : **Answered**

Chosen Option : **4**

**Q.62** Consider the elements N, P, O, S, Cl and F. The number of valence electrons present in the elements with most and least metallic character from the above list is respectively.

**Options**

1. 5 and 6
2. 6 and 7
3. 5 and 7
4. 7 and 5

Question Type : **MCQ**

Question ID : **8606541707**

Option 1 ID : **8606545808**

Option 2 ID : **8606545806**

Option 3 ID : **8606545807**

Option 4 ID : **8606545805**

Status : **Answered**

Chosen Option : **3**

Q.63

The correct order of acidic strength of the major products formed in the given reactions, is :

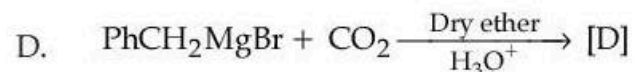
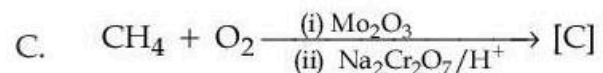
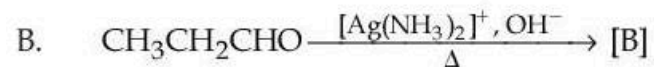
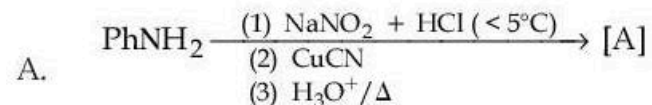

Choose the **correct** answer from the options given below :

Options

1.  $\text{A} > \text{D} > \text{B} > \text{C}$
2.  $\text{C} > \text{A} > \text{D} > \text{B}$
3.  $\text{C} > \text{B} > \text{A} > \text{D}$
4.  $\text{A} > \text{D} > \text{C} > \text{B}$

Question Type : MCQ

Question ID : 8606541716

Option 1 ID : 8606545841

Option 2 ID : 8606545843

Option 3 ID : 8606545844

Option 4 ID : 8606545842

Status : Answered

Chosen Option : 4

**Q.64** Consider the following statements about manganate and permanganate ions. Identify the **correct** statements.

- A. The geometry of both manganate and permanganate ions is tetrahedral.
- B. The oxidation states of Mn in manganate and permanganate are +7 and +6, respectively.
- C. Oxidation of Mn(II) salt by peroxodisulphate gives manganate ion as the final product.
- D. Manganate ion is paramagnetic and permanganate ions is diamagnetic.
- E. Acidified permanganate ion reduces oxalate, nitrite and iodide ions.

Choose the **correct** answer from the options given below :

**Options**

- 1. A, D and E Only
- 2. A and D Only
- 3. A, B and C Only
- 4. A, C and D Only

Question Type : **MCQ**

Question ID : **8606541709**

Option 1 ID : **8606545814**

Option 2 ID : **8606545816**

Option 3 ID : **8606545813**

Option 4 ID : **8606545815**

Status : **Answered**

Chosen Option : **4**

**Q.65** The wavelength of photon 'A' is 400 nm. The frequency of photon 'B' is  $10^{16} \text{ s}^{-1}$ . The wave number of photon 'C' is  $10^4 \text{ cm}^{-1}$ . The correct order of energy of these photons is :

**Options**

1.  $C > B > A$
2.  $B > A > C$
3.  $A > C > B$
4.  $A > B > C$

Question Type : **MCQ**

Question ID : **8606541702**

Option 1 ID : **8606545786**

Option 2 ID : **8606545787**

Option 3 ID : **8606545788**

Option 4 ID : **8606545785**

Status : **Answered**

Chosen Option : **2**

**Q.66**

Given below are two statements :

**Statement I :** The increasing order of boiling point of hydrogen halides is  $\text{HCl} < \text{HBr} < \text{HI} < \text{HF}$ .

**Statement II :** The increasing order of melting point of hydrogen halides is  $\text{HCl} < \text{HBr} < \text{HF} < \text{HI}$ .

In the light of the above statements, choose the **correct** answer from the options given below :

**Options**

1. Both **Statement I** and **Statement II** are false
2. **Statement I** is true but **Statement II** is false
3. Both **Statement I** and **Statement II** are true
4. **Statement I** is false but **Statement II** is true

Question Type : **MCQ**

Question ID : **8606541708**

Option 1 ID : **8606545810**

Option 2 ID : **8606545811**

Option 3 ID : **8606545809**

Option 4 ID : **8606545812**

Status : **Not Answered**

Chosen Option : --

Q.67

Match List - I with List - II according to shape.

**List - I**

**List - II**

- |                             |                       |
|-----------------------------|-----------------------|
| A. $\text{XeO}_3$           | I. $\text{BrF}_5$     |
| B. $\text{XeF}_2$           | II. $\text{NH}_3$     |
| C. $\text{XeO}_2\text{F}_2$ | III. $[\text{I}_3]^-$ |
| D. $\text{XeOF}_4$          | IV. $\text{SF}_4$     |

Choose the **correct** answer from the options given below :

**Options**

1. A-III, B-II, C-IV, D-I
2. A-II, B-III, C-I, D-IV
3. A-II, B-III, C-IV, D-I
4. A-II, B-I, C-III, D-IV

Question Type : **MCQ**

Question ID : **8606541706**

Option 1 ID : **8606545803**

Option 2 ID : **8606545802**

Option 3 ID : **8606545804**

Option 4 ID : **8606545801**

Status : **Answered**

Chosen Option : **3**

**Q.68** A student has been given 0.314 g of an organic compound and asked to estimate Sulphur. During the experiment, the student has obtained 0.4813 g of barium sulphate. The percentage of sulphur present in the compound is \_\_\_\_\_. (Given Molar mass in  $\text{g mol}^{-1}$  S : 32,  $\text{BaSO}_4$  : 233)

**Options**

1. 42.10%
2. 63.15%
3. 21.05%
4. 48.24%

Question Type : **MCQ**

Question ID : **8606541720**

Option 1 ID : **8606545857**

Option 2 ID : **8606545858**

Option 3 ID : **8606545860**

Option 4 ID : **8606545859**

Status : **Answered**

Chosen Option : **3**

Q.69

Consider the following reactions

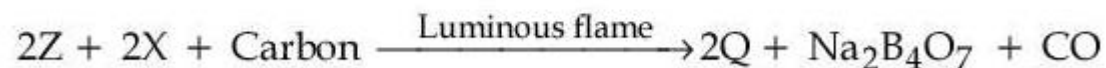
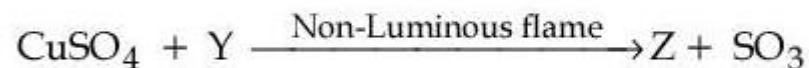

The oxidation states of Cu in Z and Q, respectively are :

Options

1. +1 and +2
2. +2 and +2
3. +1 and +1
4. +2 and +1

Question Type : **MCQ**Question ID : **8606541711**Option 1 ID : **8606545824**Option 2 ID : **8606545821**Option 3 ID : **8606545823**Option 4 ID : **8606545822**Status : **Not Answered**

Chosen Option : --

Q.70

Identify the **correct** statements :

The presence of  $-\text{NO}_2$  group in benzene ring

- A. activates the ring towards electrophilic substitutions.
- B. deactivates the ring towards electrophilic substitutions.
- C. activates the ring towards nucleophilic substitutions.
- D. deactivates the ring towards nucleophilic substitutions.

Choose the **correct** answer from the options given below :

Options

- 1. A and D Only
- 2. B and C Only
- 3. B and D Only
- 4. C and A Only

Question Type : **MCQ**

Question ID : **8606541713**

Option 1 ID : **8606545829**

Option 2 ID : **8606545831**

Option 3 ID : **8606545832**

Option 4 ID : **8606545830**

Status : **Answered**

Chosen Option : **2**

Section : **Chemistry Section B**

Q  
7  
1

For strong electrolyte  $\Lambda_m$  increases slowly with dilution and can be represented by the equation

$$\Lambda_m = \Lambda_m^\circ - Ac^{1/2}$$

Molar conductivity values of the solutions of strong electrolyte AB at 18°C are given below :

c [mol L <sup>-1</sup> ]	0.04	0.09	0.16	0.25
$\Lambda_m$ [S cm <sup>2</sup> mol <sup>-1</sup> ]	96.1	95.7	95.3	94.9

The value of constant A based on the above data [in S cm<sup>2</sup> mol<sup>-1</sup>/(mol/L)<sup>1/2</sup>] unit is \_\_\_\_\_.

G  
4  
i  
v  
e  
n  
A  
n  
s  
w  
e  
r  
:

Question Type : SA

Question ID : 8606541722

Status : Answered

Q  
7  
2 A volume of  $x$  mL of 5 M  $\text{NaHCO}_3$  solution was mixed with 10 mL of 2 M  $\text{H}_2\text{CO}_3$  solution to make an electrolytic buffer. If the same buffer was used in the following electrochemical cell to record a cell potential of 235.3 mV, then the value of  $x =$  \_\_\_\_\_ mL (nearest integer).

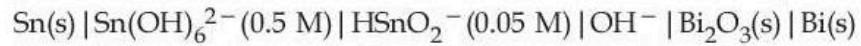

Consider upto one place of decimal for intermediate calculations

$$\left[ \begin{array}{l} \text{Given :} \quad E^\circ_{\text{HSnO}_2^- \mid \text{Sn(OH)}_6^{2-}} = -0.9 \text{ V} \\ E^\circ_{\text{Bi}_2\text{O}_3 \mid \text{Bi}} = -0.44 \text{ V} \\ \text{pK}_a(\text{H}_2\text{CO}_3) = 6.11 \\ \frac{2.303 RT}{F} = 0.059 \text{ V} \\ \text{Antilog}(1.29) = 19.5 \end{array} \right]$$

G--  
iv  
e  
n  
A  
n  
s  
w  
e  
r  
:

Question Type : SA

Question ID : 8606541723

Status : Not Answered

Q  
.  
7  
3A  $\longrightarrow$  B (first reaction)C  $\longrightarrow$  D (second reaction)

Consider the above two first-order reactions. The rate constant for first reaction at 500 K is double of the same at 300 K. At 500 K, 50% of the reaction becomes complete in 2 hour. The activation energy of the second reaction is half of that of first reaction. If the rate constant at 500 K of the second reaction becomes double of the rate constant of first reaction at the same temperature; then rate constant for the second reaction at 300 K is \_\_\_\_\_  $\times 10^{-1} \text{hour}^{-1}$  (nearest integer).

G2  
iv  
e  
n  
A  
n  
s  
w  
e  
r  
:

Question Type : SA

Question ID : 8606541724

Status : Answered

Q  
7  
4  
The number of isoelectronic species among  $\text{Sc}^{3+}$ ,  $\text{Cr}^{2+}$ ,  $\text{Mn}^{3+}$ ,  $\text{Co}^{3+}$  and  $\text{Fe}^{3+}$  is 'n'. If 'n' moles of  $\text{AgCl}$  is formed during the reaction of complex with formula  $\text{CoCl}_3(\text{en})_2\text{NH}_3$  with excess of  $\text{AgNO}_3$  solution, then the number of electrons present in the  $t_{2g}$  orbital of the complex is \_\_\_\_\_.

G  
6  
i  
v  
e  
n  
A  
n  
s  
w  
e  
r  
:

Question Type : **SA**

Question ID : **8606541725**

Status : **Answered**

Q  
7  
5

Two positively charged particles  $m_1$  and  $m_2$  have been accelerated across the same potential difference of 200 keV as shown below.

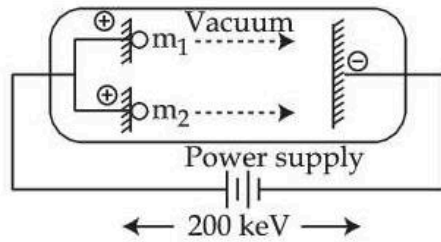

[Given mass of  $m_1 = 1$  amu and  $m_2 = 4$  amu]

The deBroglie wavelength of  $m_1$  will be  $x$  times of  $m_2$ . The value of  $x$  is \_\_\_\_\_ (nearest integer)

G2  
iv  
e  
n  
A  
n  
s  
w  
e  
r  
:

Question Type : SA

Question ID : 8606541721

Status : Answered